



FILLING, STOPPERING AND CAPPING MACHINES



Steriline
ASEPTIC PROCESSING

FILLING, STOPPERING AND CAPPING MACHINES

The modern design of STERILINE filling, stoppering and capping machines takes into consideration the newest requirements of the filling process:

- In line transport and small width, suitable for the application of open RABS, closed RABS and isolators, reduce the volume to be monitored and sterilized, and make reachable, from the operator front, any point of the machine by gloves;
- Tight mechanisms, actuated from the mechanical volume, fulfil the closed RABS and isolators tightness requirements;
- Rotating table designed to achieve easily the unidirectional and laminar air flow, reducing the presence of particles on the table;
- Continuous monitoring of the viable and non viable particles;
- Filling by peristaltic pumps and/or volumetric pumps actuated by brushless motors, that allow precise filling volume and easy adjustment of the pumps by means of the HMI;
- Nitrogen blowing inside the vials before, during and after the filling;
- 100% IPC (In Process Control) of the weight and statistical Check Weighing system with feedback to the dosing pumps;
- Possibility of performing prefilled syringes, loaded from the nests;
- Vibration generator for the bowl of stoppers inside the mechanical volume, below the process area;
- Capping designed to reduce particle generation, by rotating the glassware under the blades.



STERILINE filling machines **VFM** series handle from 2ml to 100ml vials, with minimal format changes and with production speeds up to 300 vials/min, according to vial size and filling volume. The filling machines are equipped with an infeed rotating table which feeds empty vials into the walking beam system.

The pumps in the filling section fill the

correct dosage into the vials. Filling operations are carried out in two steps by means of a stainless steel dosing nozzle mounted on an AISI316L stainless steel support.

To avoid foaming, the filling system utilizes a diving nozzle that, during the filling operation, is retracted upward. Each vial can be individually weighed before and after filling to get the net

fill weight. A feedback control loop can also be provided to automatically adjust the filling volume of each individual filling nozzle. For high speed filling machines, a statistical check weighing system is foreseen.

Vials proceed to the stopper inserting station where stoppers are fed by a vibratory feeder bowl to the stoppering unit.

VFM 50

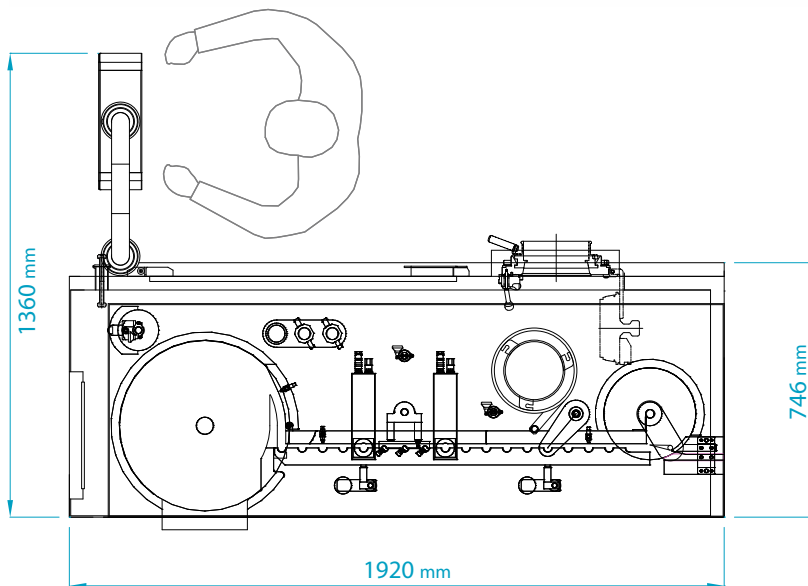

The vials are stoppered by a pick-and-place system, vacuum assisted. A sensor detects the stopper presence;

consequently the machine rejects the un-stoppered vials. Stopper may be positioned in either

a fully seated position or partially seated for products which require lyophilization. The machine can handle all standard stopper sizes: 13mm, 20mm, 28mm, 32mm.

In the STERILINE filling, stoppering and capping machines **VFCM** series, the aluminum cap sealing is on the same platform and it is performed by rotating blade and rotating vial system.

VFCM 100-S



This results in an ideal closure without disturbance of the laminar air flow over the vials and without generating any significant level of particles.

Automatic seal pressure control and rejection are available.

For vials which need to be capped after lyophilization, the capping unit can be reloaded from the rotating table through a special tray unloading

system. The filling and stoppering stations are switched off, while the crimping station caps and seals the lyophilized vials.

STERILINE filling machines **VFM-S** series perform as well Pre Filled Syringes (PFS) from 1ml to 20ml, with minimal format changes, and with production speed up to 120 PFS/min.

The stainless steel guides and the Delrin contrast plate enable the operator to load the PFS from the nests. The chute brings the PFS into the infeed star-wheel that loads the walking beam. The chute is equipped with a minimum load sensor to stop the machine when PFS are missing.

The walking beam transports the PFS through the pre-gas station, the filling

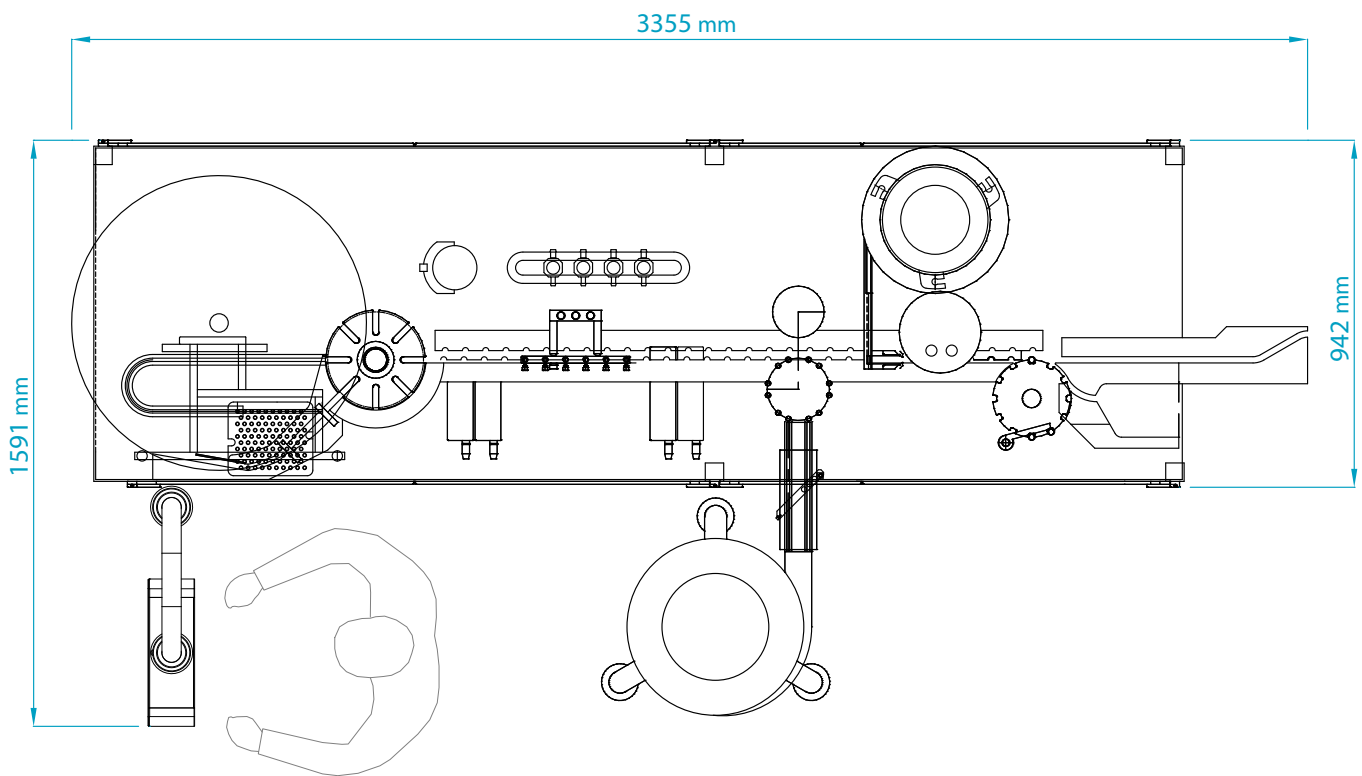

station and the post-gas station. In the bung insertion station the star-wheel handles bung stoppers fed by a vibratory feeder bowl and special double pistons insert the bung stoppers into the PFS. Incomplete syringes, without bung stopper, will be automatically rejected.

STERILINE filling machines are designed to be integrated with our superior containment systems: RABS, cRABS and Isolators.

STERILINE filling machines can be fully integrated with our washing machines, depyrogenating tunnels and external decontaminating machines for a complete solution as well as supplied stand alone.



The filling unit is designed to accept 4 volumetric pumps. The basic machine is supplied with one set of two high precision pumps for a single filling process. Two additional pumps can be supplied for a two step filling.

Pumps are made of two AISI316L stainless steel parts: the rotating piston and the cylinder. The parts are driven by servo motors with the following advantages:

- Self-priming is possible without running the machine;
- In case of suspension, product can be continuously recirculated during the machine stop;
- No vial - no fill is achieved without application of any additional device such as valves, etc.;
- Independent adjustment and fine tuning for every single pump;
- Stroke setting can be saved in the recipe and easily loaded with every size change.
- The filling accuracy is +/- 0.5% for 1ml filling volume and more, +/- 1.0% or better for less than 1ml filling volume.



STERILINE integrated 100% IPC in-line check weighing system is designed to detect the net weight of all vials in a batch.

The system is composed of tare weight cells and gross weight cells. The cells are mounted on different supports, separated from the machine frame, in order to eliminate any vibration influence on the weighing process.

Parameters, such as target weight and tolerances, can be set from the HMI and saved in the recipes.

When the filling volume is out-of tolerance, the vial is automatically rejected.





STERILINE srl - Via Tentorio, 30 - 22100 Como - ITALY
Ph. +39 031 592 064 - Fax +39 031 591 976 - www.steriline.it

